

4

3

2

1

REVISIONS - BALLOONS DENOTE CHANGES			
REV.	DESCRIPTION	DATE	APPROVED
A		4/20/2020	ZAG

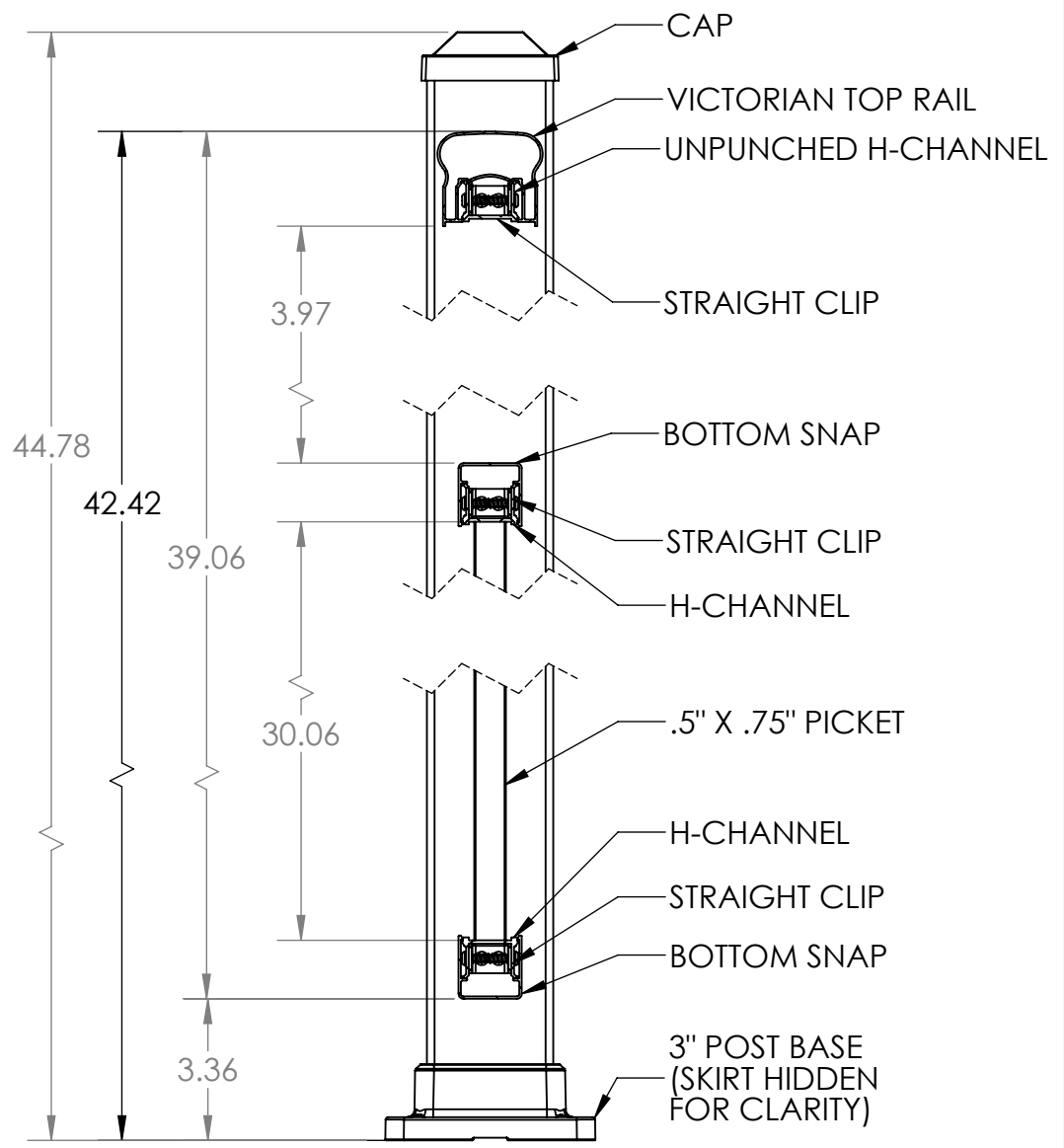
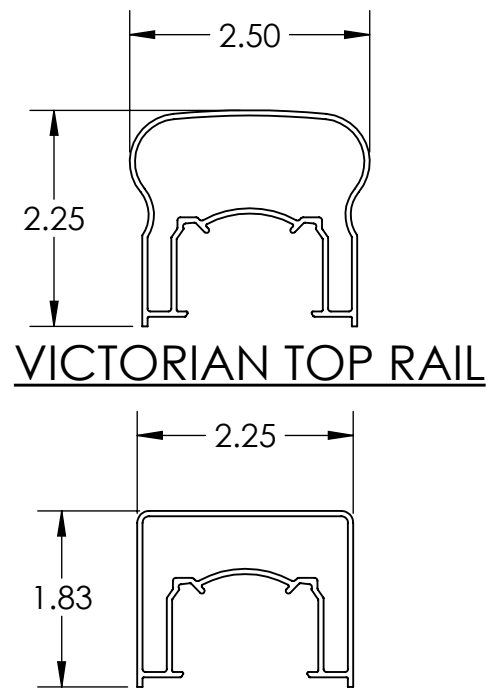
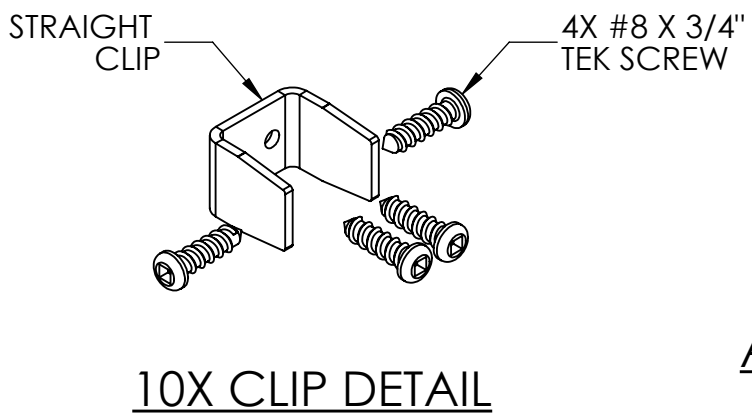
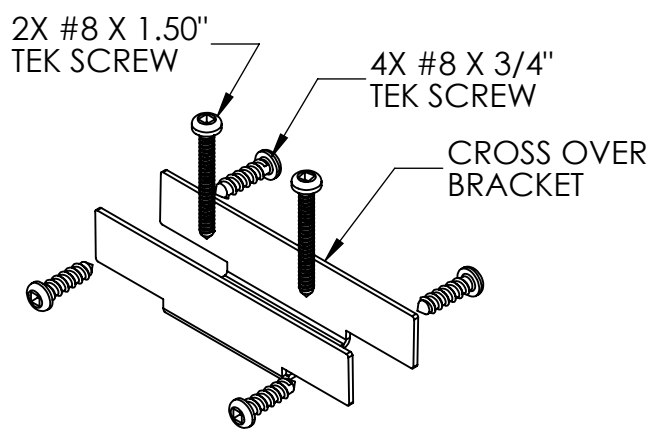
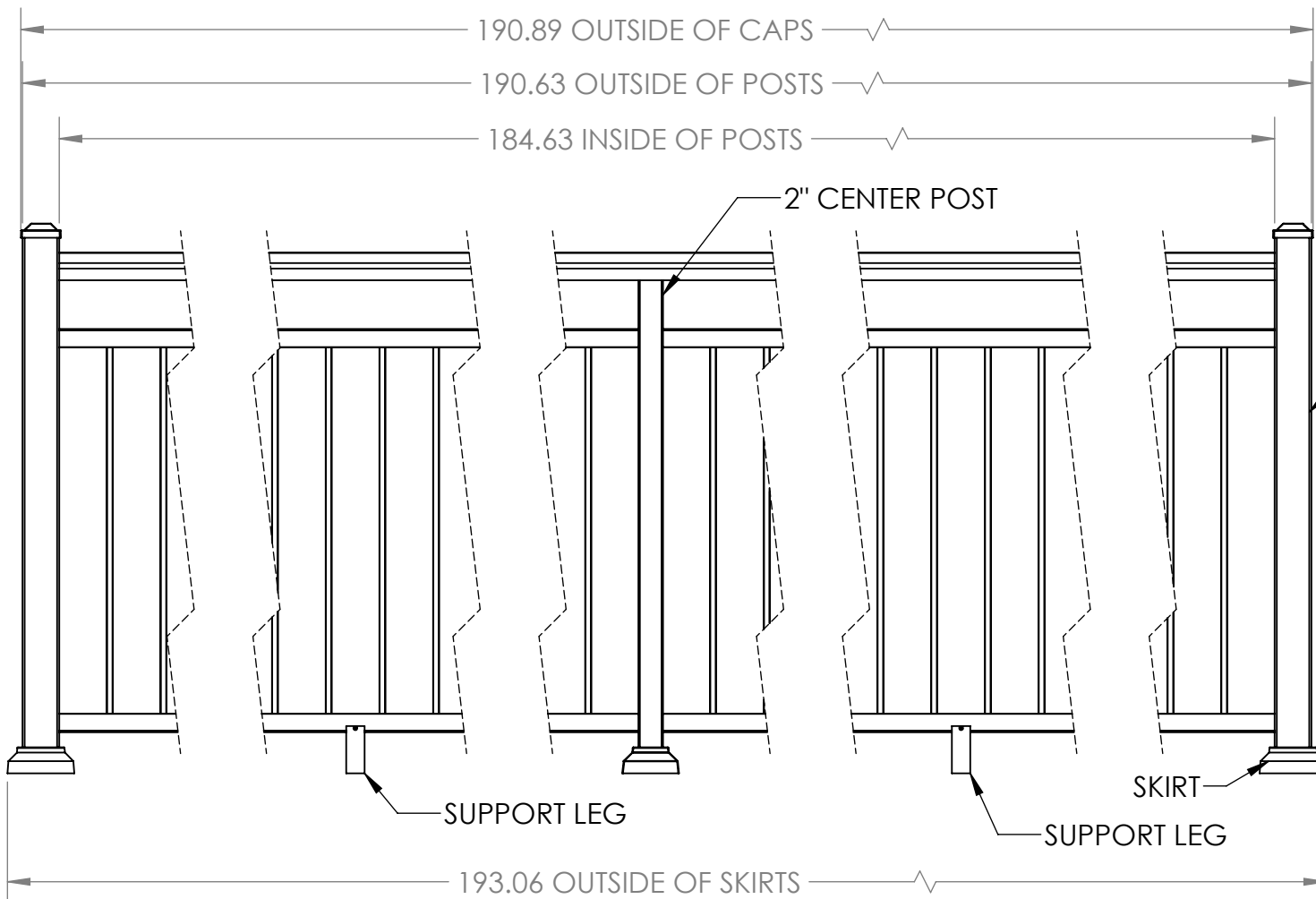

1X 2" POST CROSS OVER BRACKET (MOUNTS TO TOP OF CENTER POST)

NOTES:  
 1. ALL RAIL MUST BE ASSEMBLED AND FASTENED IN ACCORDANCE WITH ULTRALOX'S INSTALLATION INSTRUCTIONS.  
 2. AVAILABLE COLORS ARE BLACK - WHITE - BRONZE.

UNLESS OTHERWISE SPECIFIED:		NAME	DATE
DIMENSIONS ARE IN INCHES		DRAWN	DRC 4/20/20
TOLERANCES:		CHECKED	
SURFACE FINISH: 125 RMS		ENG APPR.	
ANGULAR: ±.5 DEG		MFG APPR.	
LINEAR: .X ±.02			
.XX ±.010			
.XXX ±.005			
THIRD ANGLE PROJECTION:	INTERPRET GEOMETRIC TOLERANCING PER: ASME Y14.5-2009		
MATERIAL	PROPRIETARY AND CONFIDENTIAL		
FINISH	THE INFORMATION CONTAINED IN THIS DRAWING IS THE SOLE PROPERTY OF UltraLox. ANY REPRODUCTION IN PART OR AS A WHOLE WITHOUT THE WRITTEN PERMISSION OF UltraLox.		
DO NOT SCALE DRAWING			

		TITLE:	
		COMBINATION 42" TOP RAIL PICKET INFILL WITH OPEN MID RAIL 3" END POSTS - 2" INTERMEDIATE POSTS BASE MOUNT - 8' SPANS	
SIZE	DWG. NO.	REV	
<b>B</b>		<b>A</b>	
WEIGHT:		SHEET 1 OF 1	

4

3

2

1

B

B

A

A